



# Mobile Network Camera

Quick Start Guide

# Legal Information

©2023 Hangzhou Hikvision Digital Technology Co., Ltd. All rights reserved.

## About this Manual

The Manual includes instructions for using and managing the Product. Pictures, charts, images and all other information hereinafter are for description and explanation only. The information contained in the Manual is subject to change, without notice, due to firmware updates or other reasons. Please find the latest version of this Manual at the Hikvision website (<https://www.hikvision.com/>).

Please use this Manual with the guidance and assistance of professionals trained in supporting the Product.

## Trademarks

**HIKVISION** and other Hikvision's trademarks and logos are the properties of Hikvision in various jurisdictions. Other trademarks and logos mentioned are the properties of their respective owners.

## Disclaimer

TO THE MAXIMUM EXTENT PERMITTED BY APPLICABLE LAW, THIS MANUAL AND THE PRODUCT DESCRIBED, WITH ITS HARDWARE, SOFTWARE AND FIRMWARE, ARE PROVIDED "AS IS" AND "WITH ALL FAULTS AND ERRORS". HIKVISION MAKES NO WARRANTIES, EXPRESS OR IMPLIED, INCLUDING WITHOUT LIMITATION, MERCHANTABILITY, SATISFACTORY QUALITY, OR FITNESS FOR A PARTICULAR PURPOSE. THE USE OF THE PRODUCT BY YOU IS AT YOUR OWN RISK. IN NO EVENT WILL HIKVISION BE LIABLE TO YOU FOR ANY SPECIAL, CONSEQUENTIAL, INCIDENTAL, OR INDIRECT DAMAGES, INCLUDING, AMONG OTHERS, DAMAGES FOR LOSS OF BUSINESS PROFITS, BUSINESS INTERRUPTION, OR LOSS OF DATA, CORRUPTION OF SYSTEMS, OR LOSS OF DOCUMENTATION, WHETHER BASED ON BREACH OF CONTRACT, TORT (INCLUDING NEGLIGENCE), PRODUCT LIABILITY, OR OTHERWISE, IN CONNECTION WITH THE USE OF THE PRODUCT, EVEN IF HIKVISION HAS BEEN ADVISED OF THE POSSIBILITY OF SUCH DAMAGES OR LOSS.

YOU ACKNOWLEDGE THAT THE NATURE OF THE INTERNET PROVIDES FOR INHERENT SECURITY RISKS, AND HIKVISION SHALL NOT TAKE ANY RESPONSIBILITIES FOR ABNORMAL OPERATION, PRIVACY LEAKAGE OR OTHER DAMAGES RESULTING FROM CYBER-ATTACK, HACKER ATTACK, VIRUS INFECTION, OR OTHER INTERNET SECURITY RISKS; HOWEVER, HIKVISION WILL PROVIDE TIMELY TECHNICAL SUPPORT IF REQUIRED.

YOU AGREE TO USE THIS PRODUCT IN COMPLIANCE WITH ALL APPLICABLE LAWS, AND YOU ARE SOLELY RESPONSIBLE FOR ENSURING THAT YOUR USE CONFORMS TO THE APPLICABLE LAW. ESPECIALLY, YOU ARE RESPONSIBLE, FOR USING THIS PRODUCT IN A MANNER THAT DOES NOT INFRINGE ON THE RIGHTS OF THIRD PARTIES, INCLUDING WITHOUT LIMITATION, RIGHTS OF PUBLICITY, INTELLECTUAL PROPERTY RIGHTS, OR DATA PROTECTION AND OTHER PRIVACY RIGHTS. YOU SHALL NOT USE THIS PRODUCT FOR ANY PROHIBITED END-USES, INCLUDING THE DEVELOPMENT OR PRODUCTION OF WEAPONS OF MASS DESTRUCTION, THE DEVELOPMENT OR PRODUCTION OF CHEMICAL OR BIOLOGICAL WEAPONS, ANY ACTIVITIES IN THE CONTEXT RELATED TO ANY NUCLEAR EXPLOSIVE OR UNSAFE NUCLEAR FUEL-CYCLE, OR IN SUPPORT OF HUMAN RIGHTS ABUSES.

IN THE EVENT OF ANY CONFLICTS BETWEEN THIS MANUAL AND THE APPLICABLE LAW, THE LATTER PREVAILS.

## Regulatory Information

### FCC Information

Please take attention that changes or modification not expressly approved by the party responsible for compliance could void the user's authority to operate the equipment.

#### FCC Compliance

This equipment has been tested and found to comply with the limits for a Class A digital device, pursuant to part 15 of the FCC Rules. These limits are designed to provide reasonable protection against harmful interference when the equipment is operated in a commercial environment. This equipment generates, uses, and can radiate radio frequency energy and, if not installed and used in accordance with the instruction manual, may cause harmful interference to radio communications. Operation of this equipment in a residential area is likely to cause harmful interference in which case the user will be required to correct the interference at his own expense.

#### FCC Conditions

This device complies with part 15 of the FCC Rules. Operation is subject to the following two conditions:

1. This device may not cause harmful interference.
2. This device must accept any interference received, including interference that may cause undesired operation.

### EU Conformity Statement

 This product and - if applicable - the supplied accessories too are marked with "CE" and comply therefore with the applicable harmonized European standards listed under the EMC Directive 2014/30/EU, the LVD Directive 2014/35/EU, the RoHS Directive 2011/65/EU, the RE Directive 2014/53/EU.

 2012/19/EU (WEEE directive): Products marked with this symbol cannot be disposed of as unsorted municipal waste in the European Union. For proper recycling, return this product to your local supplier upon the purchase of equivalent new equipment, or dispose of it at designated collection points. For more information see: [www.recyclethis.info](http://www.recyclethis.info)



 2006/66/EC (battery directive): This product contains a battery that cannot be disposed of as unsorted municipal waste in the European Union. See the product documentation for specific battery information. The battery is marked with this symbol, which may include lettering to indicate cadmium (Cd), lead (Pb), or mercury (Hg). For proper recycling, return the battery to your supplier or to a designated collection point. For more information see: [www.recyclethis.info](http://www.recyclethis.info)

### Industry Canada ICES-003 Compliance

This device meets the CAN ICES-3 (A)/NMB-3(A) standards requirements.

## Symbol Conventions

The symbols that may be found in this document are defined as follows.

Symbol	Description
 <b>Note</b>	Provides additional information to emphasize or supplement important points of the main text.
 <b>Caution</b>	Indicates a potentially hazardous situation, which if not avoided, could result in equipment damage, data loss, performance degradation, or unexpected results.
 <b>Danger</b>	Indicates a hazard with a high level of risk, which if not avoided, will result in death or serious injury.

## Safety Instructions

- Proper configuration of all passwords and other security settings is the responsibility of the installer and/or end-user.
- In the use of the product, you must be in strict compliance with the electrical safety regulations of the nation and region. Please refer to technical specifications for detailed information.
- Input voltage should meet limited power source or PS2 requirements according to the IEC60950-1 or IEC 62368-1 standard. Please refer to technical specifications for detailed information.
- Do not connect several devices to one power adapter as adapter overload may cause overheating or a fire hazard.
- Please make sure that the plug is firmly connected to the power socket.
- If smoke, odor or noise rise from the device, turn off the power at once and unplug the power cable, and then please contact the service center.

# TABLE OF CONTENTS

<b>Chapter 1 Product Introduction .....</b>	<b>1</b>
<b>Chapter 2 Camera Installation and Component Description .....</b>	<b>2</b>
2.1 XM61 Camera .....	2
2.1.1 Appearance .....	2
2.1.2 Packing List .....	2
2.1.3 Cable Description .....	4
2.1.4 Installation Instructions .....	4
2.2 XM67 Camera .....	8
2.2.1 Appearance .....	8
2.2.2 Packing List .....	9
2.2.3 Cable Description .....	9
2.2.4 Installation Instructions .....	10
2.3 XM62 Camera .....	14
2.3.1 Appearance .....	14
2.3.2 Packing List .....	14
2.3.3 Cable Description .....	15
2.3.4 Installation Instructions .....	15
<b>Chapter 3 Vehicle Network Interface Description.....</b>	<b>18</b>
<b>Chapter 4 Waterproof Tape Installation.....</b>	<b>19</b>
<b>Chapter 5 Install the Waterproof Jacket of the Mesh Opening. ....</b>	<b>21</b>
<b>Chapter 6 Quick Operation .....</b>	<b>23</b>
6.1 Connection Network .....	23
6.2 Activating and Configuring Cameras.....	23
<b>Chapter 7 Maintenance Instruction .....</b>	<b>26</b>
7.1 Lens Maintenance .....	26
7.2 Maintenance of Hemispherical Transparent Spherical Cover .....	26
7.3 Maintenance of Infrared Camera Glass .....	26
7.4 Network Security Maintenance .....	26

# Chapter 1 Product Introduction

This mobile network camera is a digital monitoring product that integrates video and audio collection, intelligent coding and compression, network transmission and other functions, and is generally used for monitoring scenes inside buses. With embedded operating system and high-performance hardware processing platform, it has high stability and reliability.

You can browse real-time video and configure settings through browser.

Main features include:

- Adopt high-performance processing chip and platform, with reliable and stable performance
- Advanced video compression technology is adopted, with high compression ratio, flexible processing and ultra-low bit rate
- It supports high-resolution video output, and the captured images are clear and delicate
- Support Micro SD card storage
- Support the functions of motion detection and occlusion alarm
- Support network remote upgrade and realize remote maintenance
- Support a variety of intelligent alarm functions
- Multilingual support
- Multi-browser support

---

 **Note**

Some functions of network cameras depend on specific models, please refer to the actual functions.

---

## Chapter 2 Camera Installation and Component Description

This series of mobile network cameras have various appearances. Such as: XM61 camera, XM62 camera, XM67 camera, etc.

### 2.1 XM61 Camera

#### 2.1.1 Appearance

XM61 camera, as shown in the following figure.

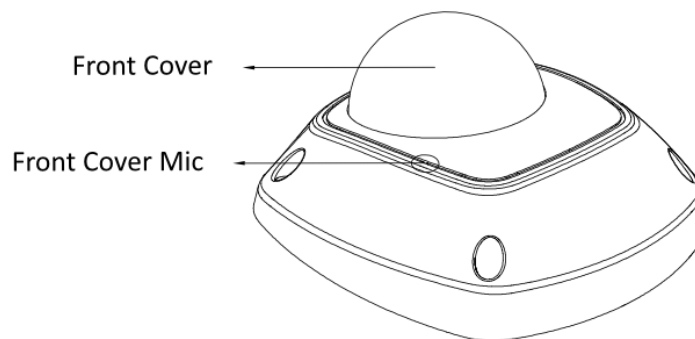

Figure 2-1 The Exterior of XM61 Camera

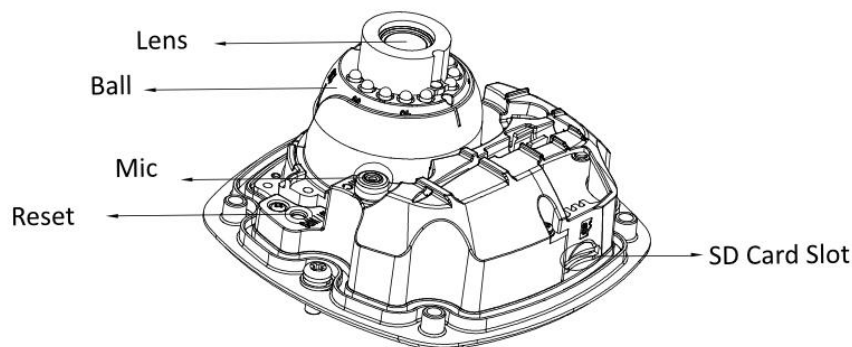

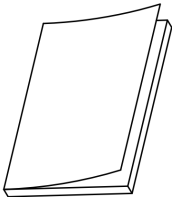
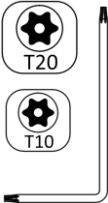

Figure 2-2 The Interior of XM61 Camera



- Microphone: used to collect audio.
- Micro SD card slot: used to insert Micro SD card for local storage.
- RESET key: press the "RESET" key for a long time, and then power on the camera; when the camera is powered on, press it for 10 seconds and then release the "RESET" button. At this time, all parameters of the camera will be restored to factory settings. Please reactivate the camera after recovery.

#### 2.1.2 Packing List

Check whether the items in the packing list are complete in the packing list before installation.

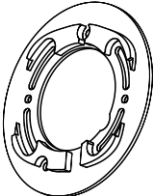
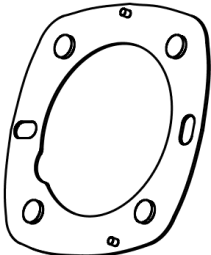
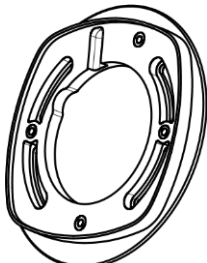
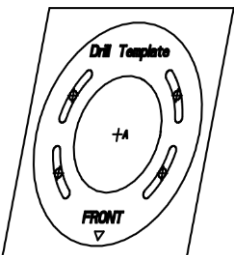
Table 2-1 Packing list of XM61

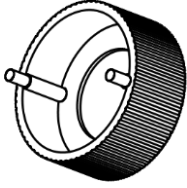
No	Picture	Name	Number
1		QSG and QUG	2
2		L Shape Wrench	1
3		PA4x25 Screw	1
4		Adapter Plate Shock Absorption Pad	1
5		Body Shock Absorption Pad	1
6		Adapter Plate	1
7		Drill Template	1

No	Picture	Name	Number
8		Adjusting Handle	1
9		M4x10 Screw	2

### 2.1.3 Cable Description

There are 4 types of cables for XM61 cameras, as shown in Figure 2-3 . Please refer to the relevant instructions according to the physical equipment.

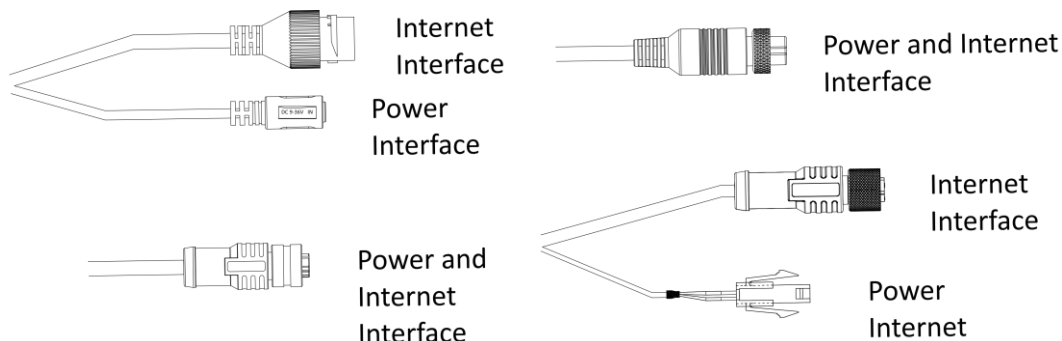

Figure 2-3 XM61 Camera Cable

- **Power Interface:** The camera power supply supports DC 9-36 V power supply mode. Please connect the positive and negative poles of the power supply correctly. According to the camera model, there are three kinds of interfaces, the left side of the upper row is DC interface, the right side of the upper row is 6-core aviation head interface, the lower left row is 4-core aviation head interface and the lower right is Molex interface.
- **Network interface:** network signal output. According to the camera model, there are three kinds of interfaces: RJ45 interface on the left side of the upper row, 6 cores Aviation head interface on the right side of the upper row and 4 cores Aviation head interfaces on the lower row.

 **Note**

The appearance and cable of the camera depend on the model, please refer to the actual equipment.

### 2.1.4 Installation Instructions

The XM61 camera installation steps are as follows

Step 1 Stick the drill template to the appropriate installation position, and make a hole according to the sticker size, insert the plastic jacket in the hole position, then install the adapter plate shock absorption pad, the adapter plate and body shock absorption pad, and finally tighten the fixing screws.

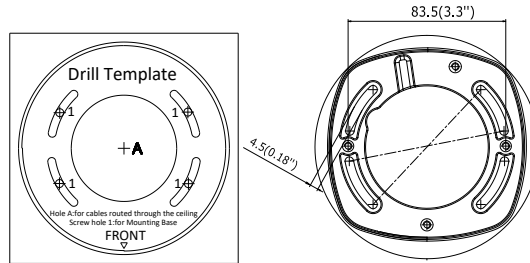

Figure 2-4 Drill Templates and Adapter Plate

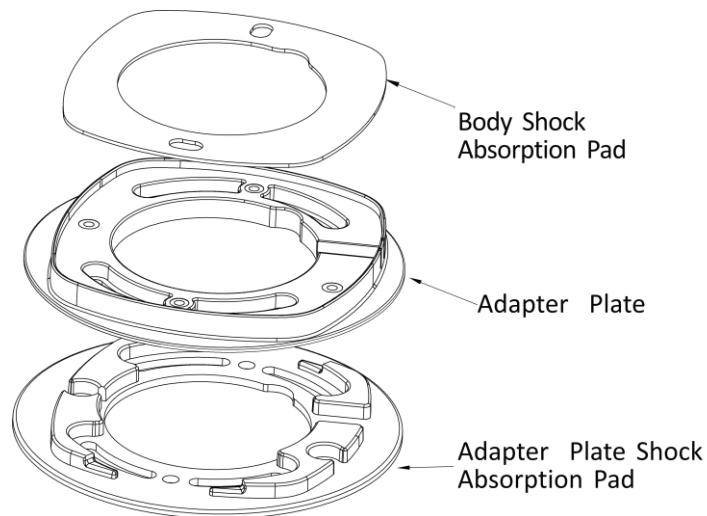

Figure 2-5 Shock Absorption Pads and Adapter

Step 2 Remove the front cover of the camera with the accompanying hex wrench.

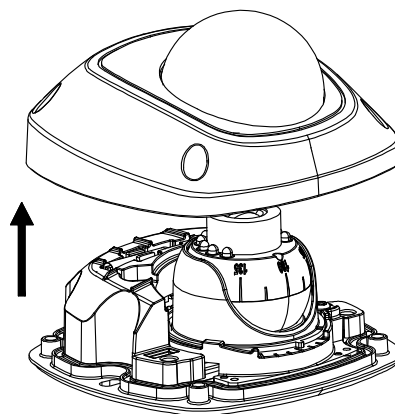

Figure 2-6 Removing Front Cover

Step 3 Gently insert the Micro SD card into the slot to complete the installation. To remove the Micro SD card, please press the Micro SD card slightly inward first, and the elastic device inside the camera slot can pop the Micro SD card out and take it out.

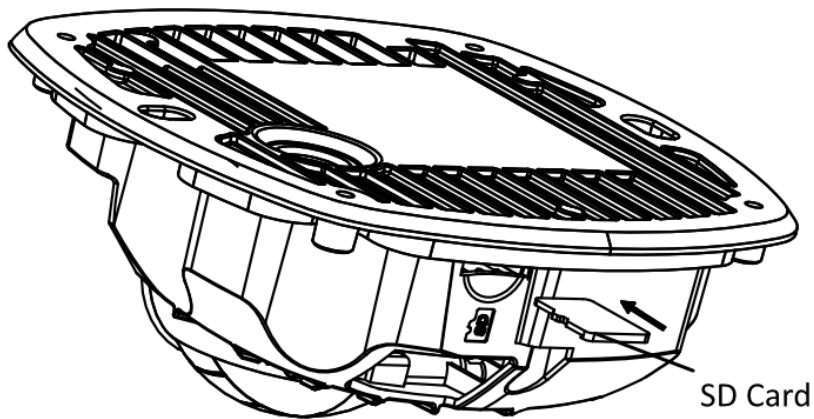

Figure 2-7 Install Micro SD Card

Step 4 Arrange and connect the power cord, network cable and other cables of the camera, and insulate the power cord.

If the cables need to be connected from the side during actual use, please use pliers to remove the blocking piece of the outlet hole on the side of the adapter plate first, and then pass the cables such as the power cord through this hole and fix them on the installation surface, thus avoiding opening holes on the installation surface to place relevant wiring and simplifying the installation process.

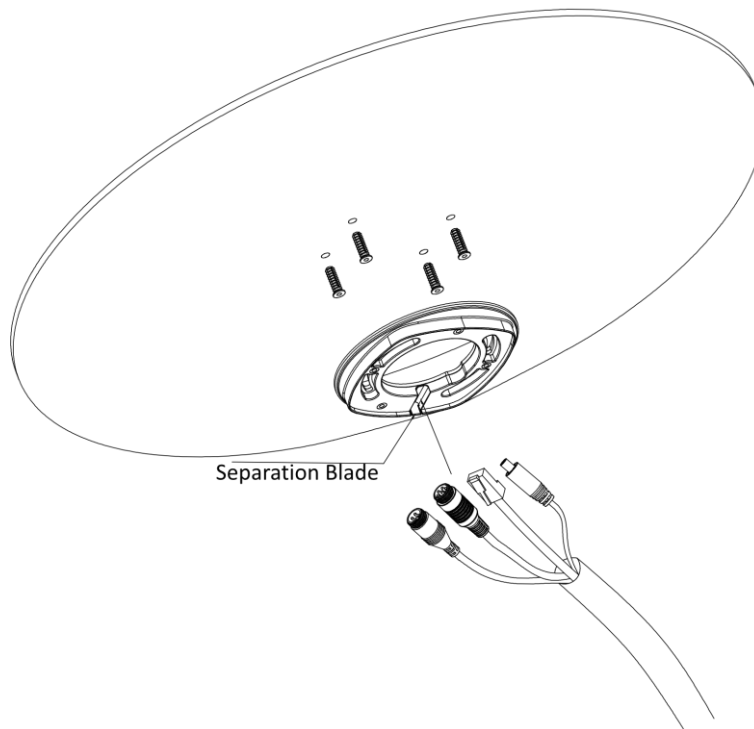

Figure 2-8 Side Outgoing Line

If the line needs to go under the camera, then follow the following figure to place the cable and screws.

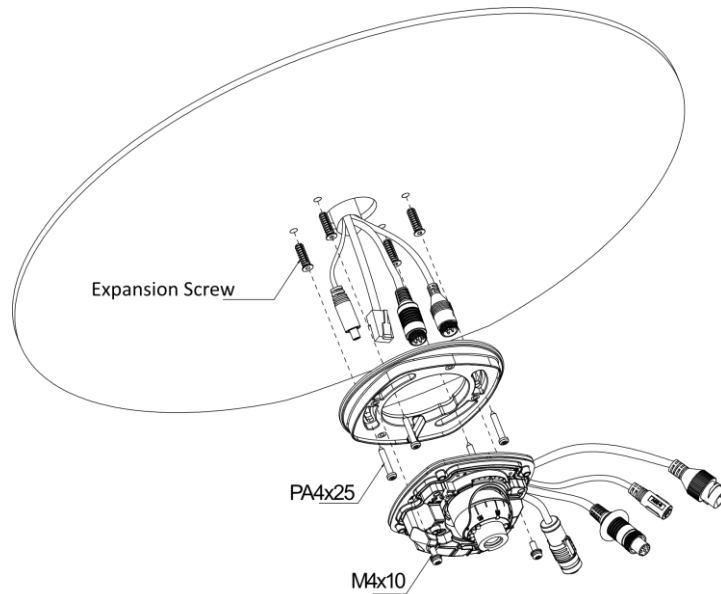

Figure 2-9 Bottom Outgoing Line

Step 5 Secure the camera base.

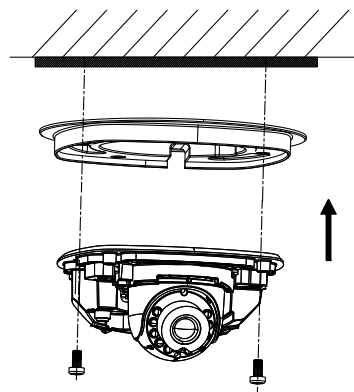

Figure 2-10 Fixed Base

Step 6 Loosen the locking screw of the camera's three-axis adjustment, and then attach the attached three-axis adjustment handle, as shown in Figure 2-11. The horizontal direction, vertical direction and rotation direction can be adjusted by the adjusting handle, and the camera picture can be adjusted to the required scene.

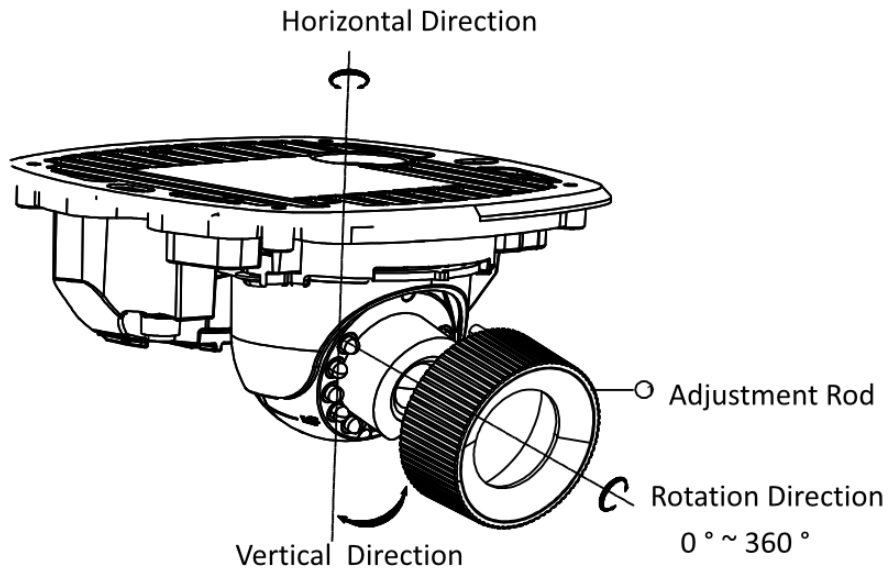

Figure 2-11 Adjusting Angle

Step 7 Install the camera front cover according to the method of removing the front cover, and complete the installation.

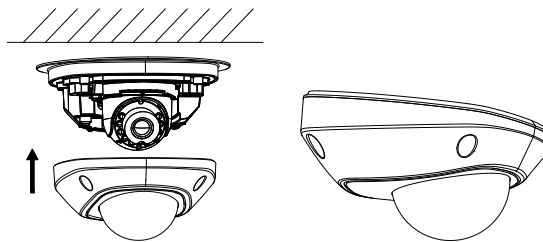

Figure 2-12 Installing Front Cover

**Note**

If this model camera does not use Micro SD card, the installation step can skip step 3.

## 2.2 XM67 Camera

### 2.2.1 Appearance

The appearance of XM67 camera, as shown in the following figure.

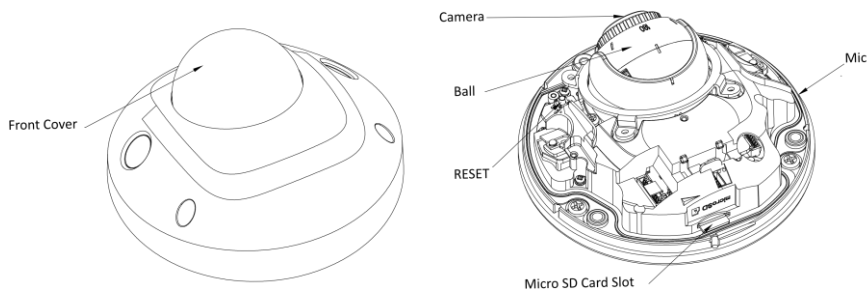

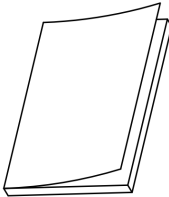
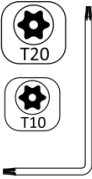

Figure 2-13 The Appearance of XM67 Camera

- Microphone: used to collect audio.
- Micro SD card slot: used to insert Micro SD card for local storage.
- RESET key: press the "RESET" key for a long time, and then power on the camera; when the camera is powered on, press it for 10 seconds and then release the "RESET" button. At this time, all parameters of the camera will be restored to factory settings. Please reactivate the camera after recovery.

### 2.2.2 Packing List

Check whether the items in the packing list are complete in the packing list before installation.

Table 2-2 Packing list of XM67

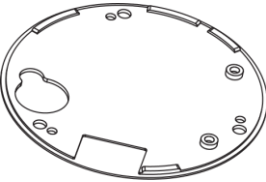
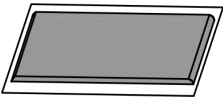
No	Picture	Name	Number
1		QSG and QUG	2
2		L Shape Wrench	1
3		PA4x25 Screw	1
4		M4x14 Screw	3
5		Body Shock Absorption Pad	1
6		Water Proof Tape	2

### 2.2.3 Cable Description

There are 4 types of cables for XM67 cameras, as shown bellow. Please refer to the relevant instructions according to the physical equipment.

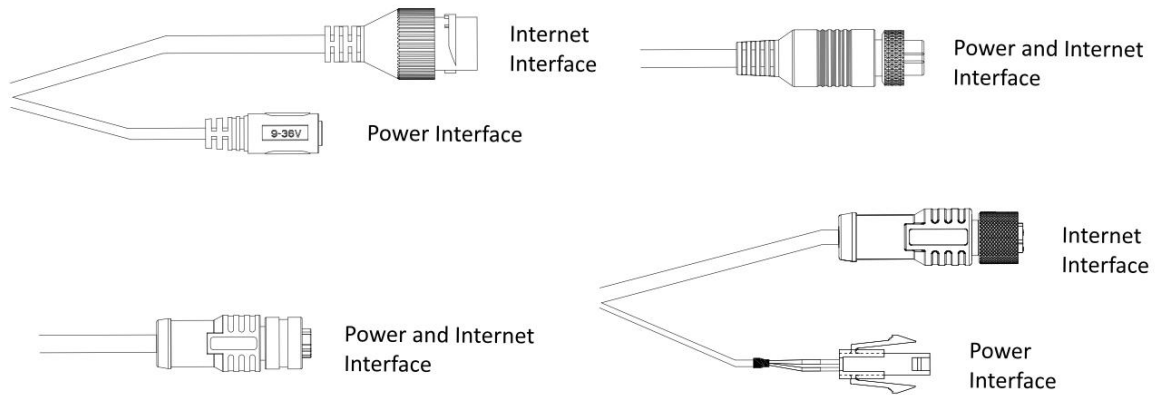

Figure 2-14 XM67 camera cable

- **Power Interface:** The camera power supply supports DC 9-36V power supply mode. Please connect the positive and negative poles of the power supply correctly. According to the camera model, there are three kinds of interfaces, the left side of the upper row is DC interface, the right side of the upper row is 6-core aviation head interface, the lower left row is 4-core aviation head interface and the lower right is Molex interface.
- **Network interface:** network signal output. According to the camera model, there are three kinds of interfaces: RJ45 interface on the left side of the upper row, 6 cores Aviation head interface on the right side of the upper row and 4 cores Aviation head interfaces on the lower row.

**Note**

The appearance and cable of the camera depend on the model, please refer to the actual equipment.

## 2.2.4 Installation Instructions

The XM67 camera installation steps are as follows.

**Step 1** Loosen the three fixing screws on the camera front cover, and remove the camera front cover.

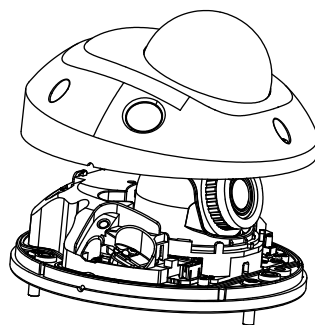

Figure 2-15 Removing Front Cover

**Step 2** Remove the cover of the Micro SD card slot, and gently insert the Micro SD card into the slot.

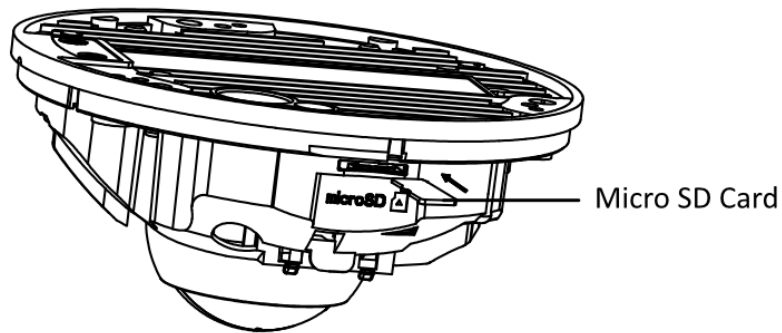

Figure 2-16 Micro SD Card Installation

---

**Note**

When removing the card cover, do not pull hard, so as not to cause the card cover to break. To take out the Micro SD card, gently press the Micro SD card inward, and the Micro SD card will automatically pop out.

If you don't use Micro SD card, you can skip step 2.

---

Step 3 According to the position of the screws and harness on the camera chassis, make holes in the car body.

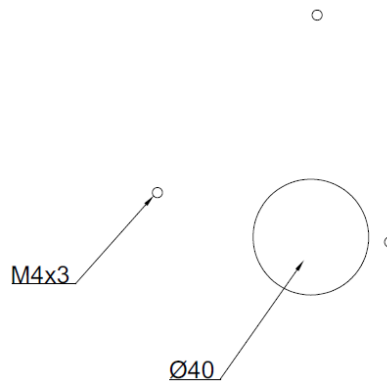

Figure 2-17 Body Opening

Step 4 Use screws to fix the body ground wire to the camera chassis.

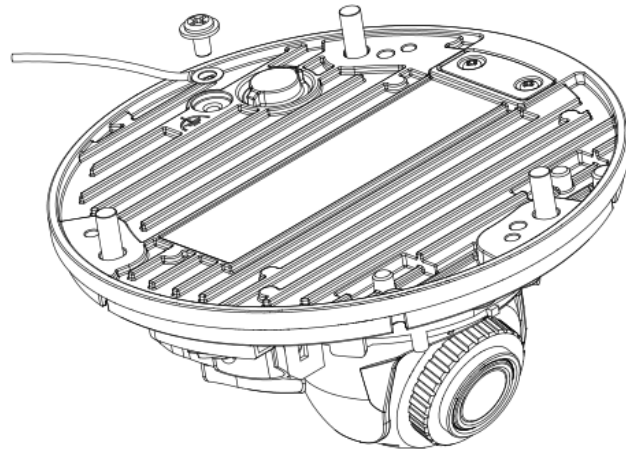

Figure 2-18 Install Ground Wire

Step 5 Use three M4×14 stainless steel combination anti-falling screws to fix the camera base to the mounting surface.

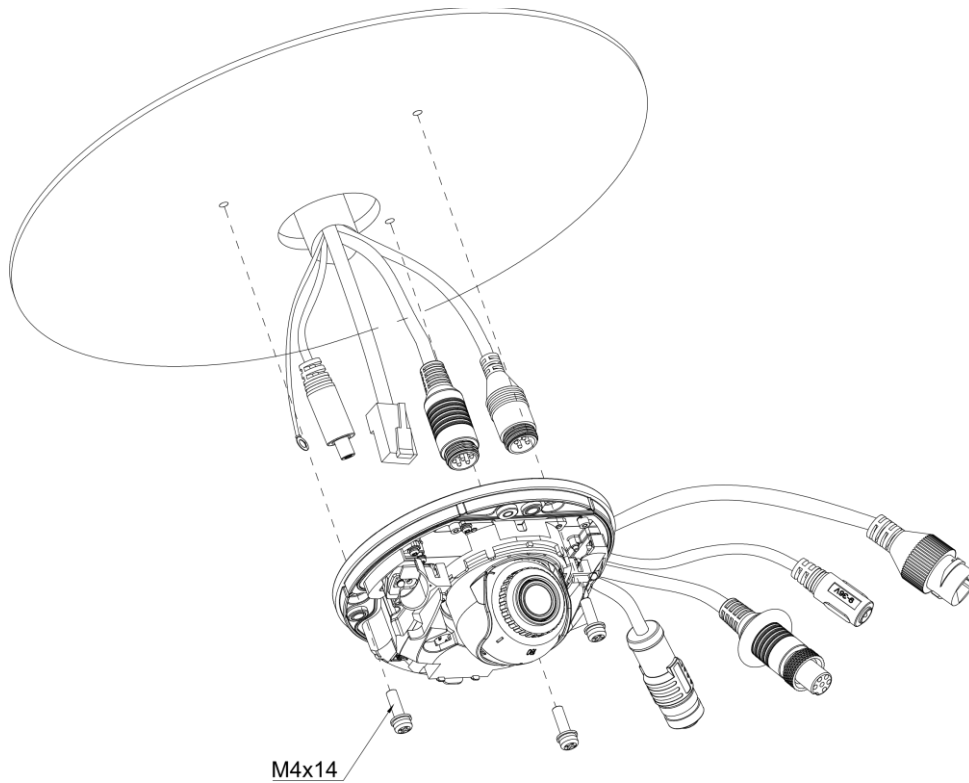

Figure 2-19 Fix Base

Step 6 Adjust the angle of the camera.

- 1) Loosen (do not unscrew) the ball core locking screw on the base.

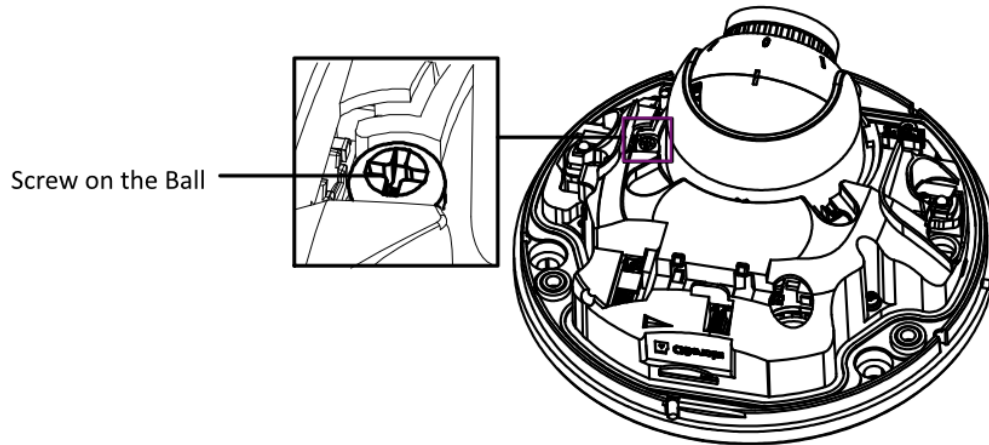

Figure 2-20 Loosen the locking screw.

- 2) Rotate the base to adjust the angle of the camera in the horizontal direction, rotate the ball core to adjust the angle of the camera in the vertical direction, and rotate the lens to adjust the angle of the camera's rotation direction. After adjusting the camera to the scene to be monitored, tighten the locking screw.

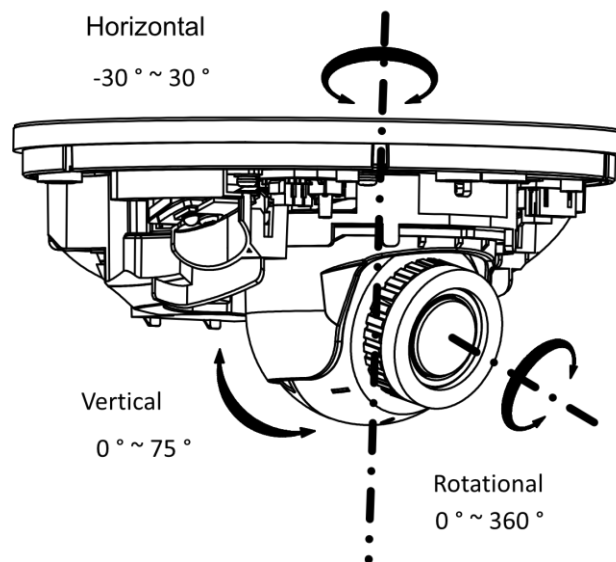

Figure 2-21 Adjusting Angle

Step 7 Align the screw holes on the front cover and the base, tighten three fixing screws, fix the front cover of the camera, and complete the installation.

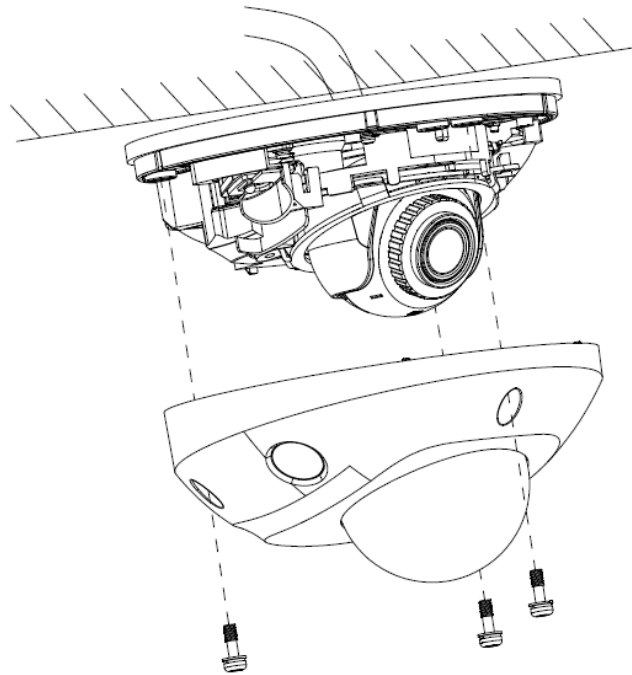

Figure 2-22 Installing front cover

## 2.3 XM62 Camera

### 2.3.1 Appearance

The appearance of XM62 camera are shown in the following figure.

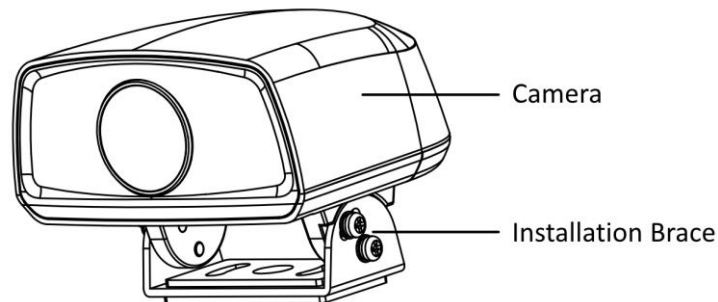

Figure 2-23 The Appearance of XM62 Camera

---

#### Note



XM62 camera can support Micro SD card, which has certain storage function. However, it is not recommended to disassemble it to get the card without permission. The customer is advised to order the model with built-in SD card.

---

### 2.3.2 Packing List

Check whether the items in the packing list are complete in the packing list before installation.

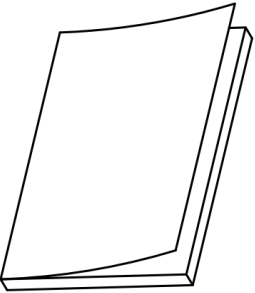
Table 2-3 Packing list of XM62

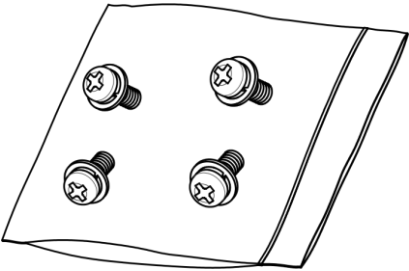
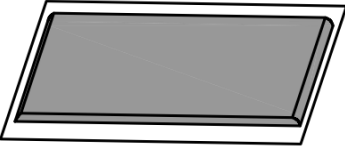
No	Picture	Name	Number
1		QSG and QUG	2
2		Drill Template	1
3		M4x16 Screw	1
4		Water Proof Tape	2

### 2.3.3 Cable Description

The cable of XM62 camera is consistent with that of XM67 camera. Please refer to Figure 2-14 for cable description.

### 2.3.4 Installation Instructions

The XM62 camera installation steps are as follows.

Step 1 Select a suitable installation plane, take out the attached drill template, and open two installation holes on the installation plane according to the sticker hole position.

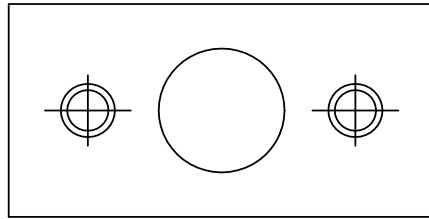

Figure 2-24 Install Stickers

Step 2 Loosen the fixing screws on both sides of the bracket and remove the camera bracket.

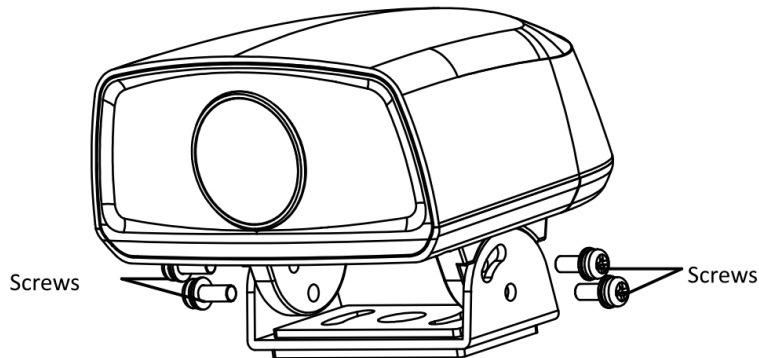

Figure 2-25 Removing Camera Bracket

Step 3 Take out the spring plate and the flat gasket that are attached with you, and insert the mounting screws in turn.

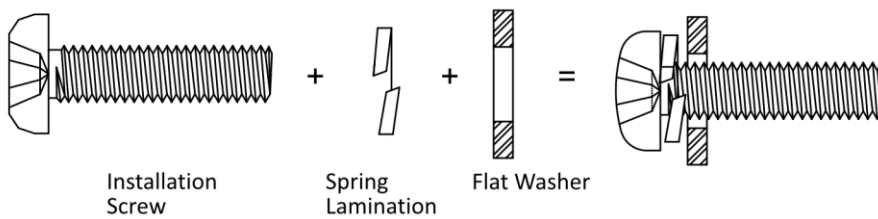

Figure 2-26 Assemble Screws

Step 4 Align the hole position of the camera bracket with the opening position of the mounting sticker, fix the bracket to the mounting plane with the assembled mounting screws, and screw on the fixing nuts (do not tighten).

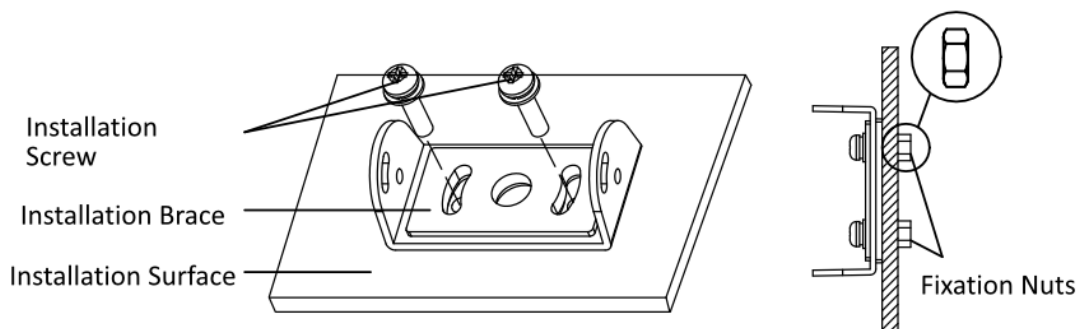

Figure 2-27 Installing Support

Re-install the camera to the corresponding position of the bracket, and arrange and connect the power cord, network cable and other cables of the camera without installing screws first; Compare the video images on the monitor and adjust the camera to the scene to be monitored. After the adjustment, tighten the fixing screws and nuts, and take waterproof protection and insulation measures for the power cord. Complete the camera installation.

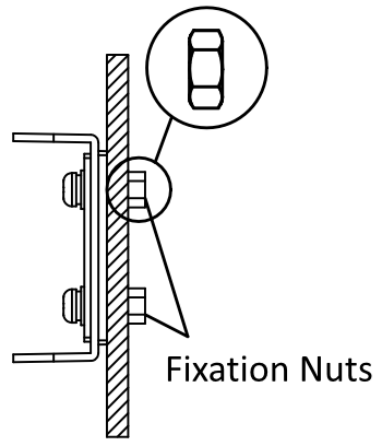

Figure 2-28 Fixation Nuts

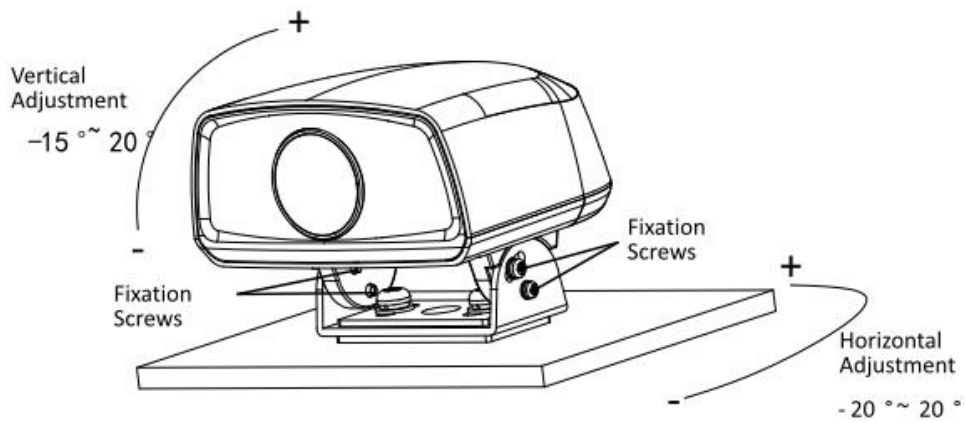

Figure 2-29 Adjusting Angle

## Chapter 3 Vehicle Network Interface Description

Interfaces of vehicle network can be divided into 4-core interface and 6-core interface, as shown in the following tables.

Table 3-1 4-Core Interface

		Aviation head interface
	TX+	1
	TX-	3
	RX+	2
	RX-	4

Table 3-2 6-Core Interface

		Aviation head interface
	TXP	2
	TXN	1
	RXP	5
	RXN	4
	VCC	3
	GND	6

## Chapter 4 Waterproof Tape Installation

Some network cameras are shipped with waterproof tape. The installation steps of waterproof tape are as follows.

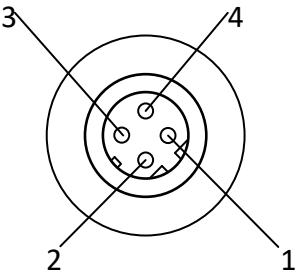
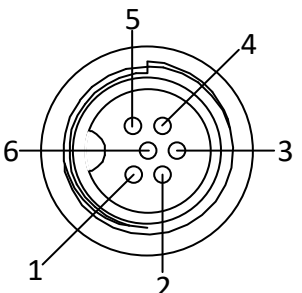
Step 1 Tear off the yellow release paper on the back of the accompanying waterproof tape.

Step 2 Stretch the waterproof tape to both ends to about 2 times the initial length, as shown in Figure 4-1.

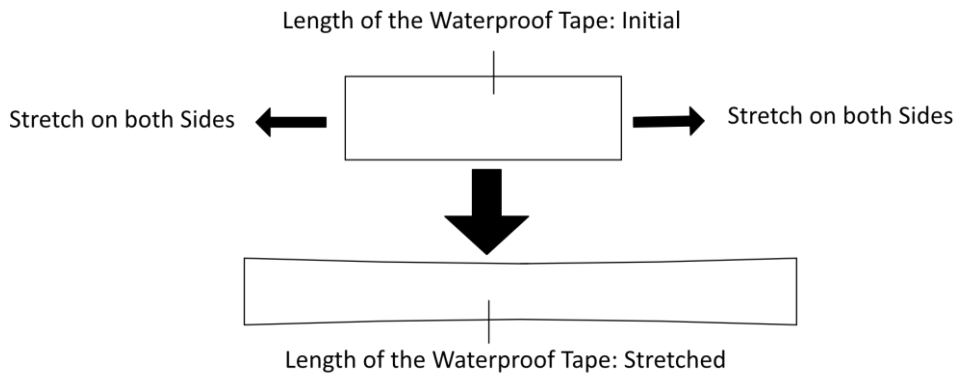

Figure 4-1 Stretch Waterproof Tape

Step 3 After stretching, the waterproof tape is tightly wound on the terminal and the nearby cables in a half-lap way until the terminal and the nearby cables are wrapped in the waterproof tape. Please pay attention to keep the waterproof tape taut during the winding process, as shown in Figure 4-2.

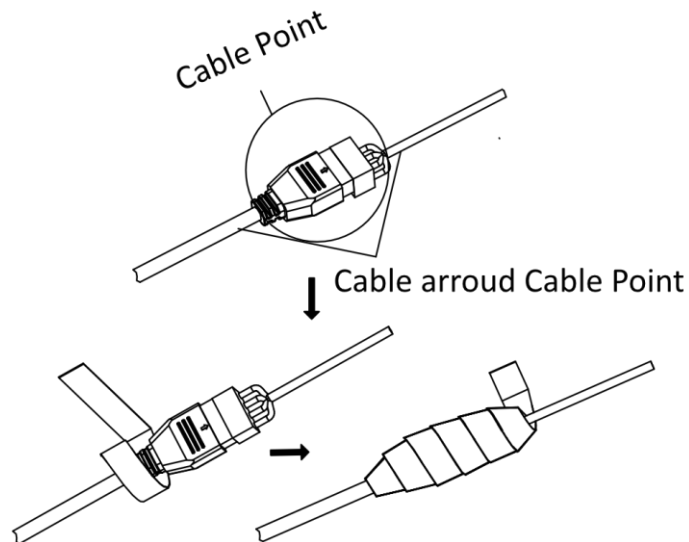

Figure 4-2 Wrapped Waterproof Tape

Step 4 As shown in Figure 4-3, press the waterproof tape on both sides of the terminal to achieve insulation and sealing.

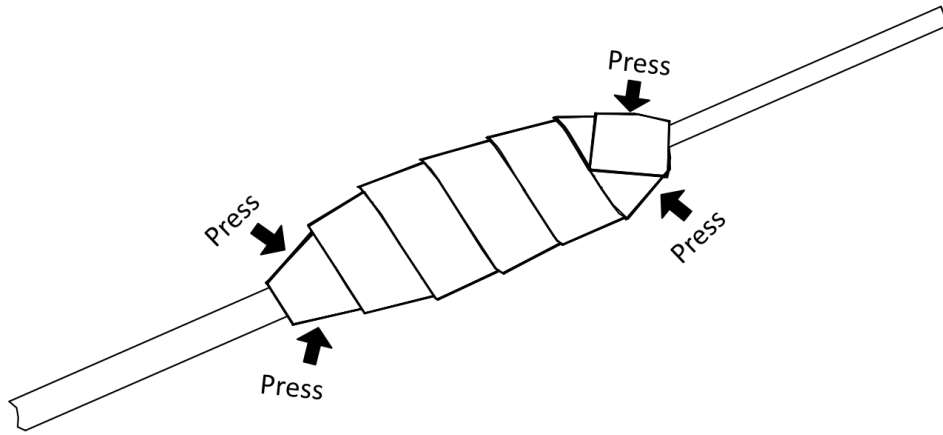

Figure 4-3 Compaction Waterproof Tape

## Chapter 5 Install the Waterproof Jacket of the Mesh Opening.

When using the camera, the matching waterproof jacket of the network port can prevent the network cable from entering water. Please install it according to the requirements.

Step 1 Pass the net cable through the fixation nut and the waterproof jacket body in turn.

Step 2 Break the waterproof rubber ring and insert it into the net between the waterproof jacket body and the fastening nut.

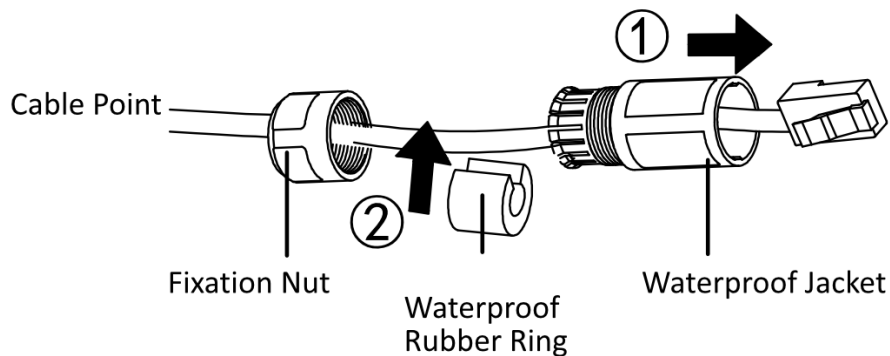

Figure 5-1 Install Waterproof Rubber Ring

Step 3 Insert the O-shaped rubber jacket into the net port and insert the network cable into the net port.

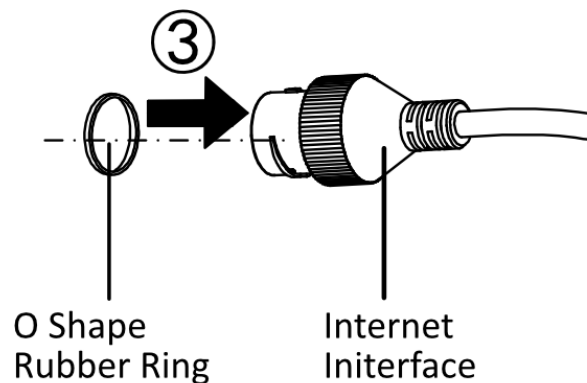

Figure 5-2 Install Network Cable

Step 4 Align the gap of the net opening with the buckle of the waterproof jacket body, jacket the waterproof jacket body into the net opening end, and tighten clockwise.

Step 5 Plug the waterproof rubber ring into the waterproof cap body.

Step 6 Rotate the fastening nut clockwise to compress the waterproof rubber ring.

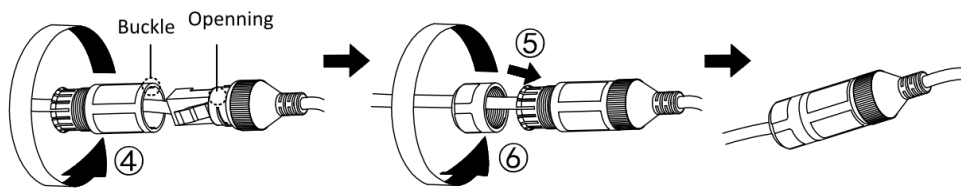

Figure 5-3 Complete Installation

## Chapter 6 Quick Operation

---

### Note

If you connect your products to the Internet at your own risk, including but not limited to network attack, hacker attack, virus infection, etc., our company will not be responsible for the problems such as abnormal product work and information leakage, but we will provide you with product-related technical support in time.

---

### 6.1 Connection Network

After the network camera is installed, you need to configure the functions and parameters. You can configure the related functions through the browser.

Before configuration, please confirm that the network camera is connected to the computer and can access the network camera that needs to be set up.

### 6.2 Activating and Configuring Cameras

The network camera must be activated and set a login password before it can log in and use normally.

---

### Note

In order to protect your personal privacy and corporate data, and avoid the network security problems of camera products, it is recommended that you set a high-strength password that meets the security specifications.

---

The network camera can be activated through SADP software, client software and browser. Please refer to the Operation Manual of Network Camera for specific activation methods.

This manual takes SADP software activation as an example, and its operation is as follows.

Step 1 Install the SADP software downloaded from official website. After running the software, the SADP software will automatically search all online devices in the local area network, and the information such as device type, IP address, activation status, serial number and so on will be displayed in the list. SADP software download address:  
[https://www.hikvision.com/cn/download\\_60.html](https://www.hikvision.com/cn/download_60.html)

---

### Note

The default IP address of network camera: 192.168.1.64.

---

Step 2 Check the device to be activated, set the device password at "Activate Device", and click "Activate" to complete activation, as shown in Figure 6-1.

 **Note**

In order to improve the security of product network use, the set password should be 8~16 digits in length, at least composed of two or more types of numbers, lowercase letters, uppercase letters and special characters, and the password should not contain the user name.

After successfully activating the device, the "activation status" in the list will be updated to "activated".

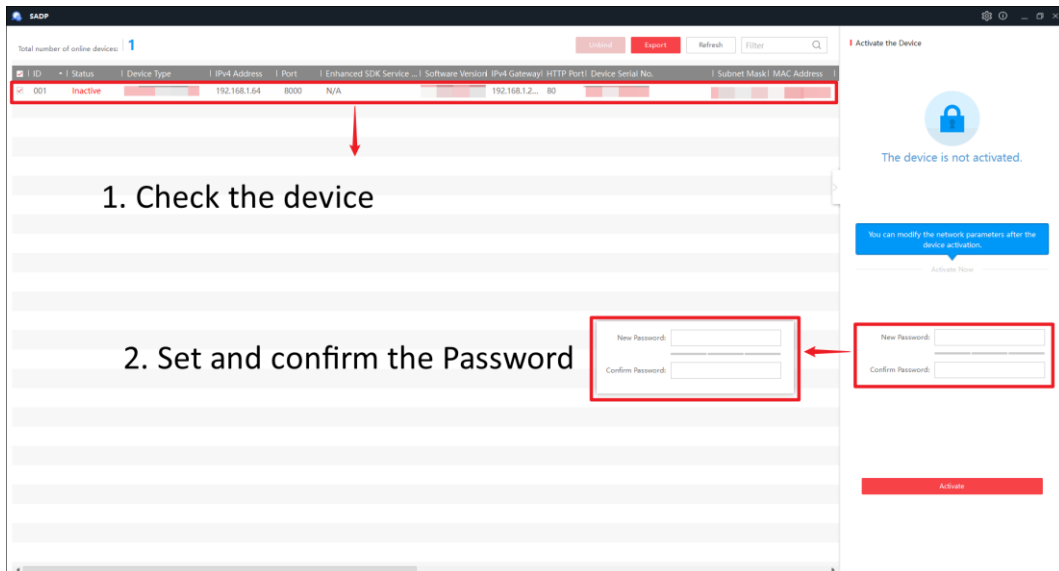

Figure 6-1 Activate Camera

**Step 3 Modify the IP address of the device**

Check the activated device, enter the IP address, subnet mask, gateway and other information in "Modify Network Parameters" on the right, and enter the password of the device. Click "Modify", and the prompt "Modify Network Parameters Successfully" indicates that the network parameter setting takes effect, as shown in Figure 6-2 .

**Note**

When setting the IP address of the network camera, keep the IP address of the device and the IP address of the computer in the same network segment.

If you are using a webcam for the first time, it is recommended to add a custom user.

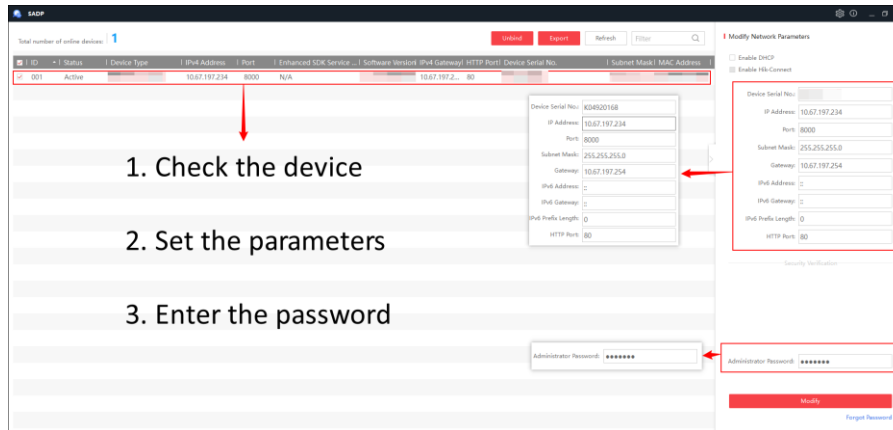

Figure 6-2 Modify Camera Information

## Chapter 7 Maintenance Instruction

### 7.1 Lens Maintenance

The surface of the lens is coated with anti-reflection coating. When it is stained with dust, grease, fingerprints, etc., harmful substances will be produced, which will lead to its performance degradation or scratch, mildew, etc. Once dirt is found, please treat it as follows.

- Dust contamination: Use an oil-free soft brush or a blowing ball to gently bounce off dust.
- Grease contamination: gently wipe the water drops or oil with a soft cloth and dry it, then use oil-free cotton cloth or lens cleaning paper to soak it in alcohol or lens cleaning solution and wipe it from the center of the lens. If it is still not wiped, you can change cloth and wipe it several times.

### 7.2 Maintenance of Hemispherical Transparent Spherical Cover

The transparent spherical cover is made of transparent plastic. If it is stained with dust, grease, fingerprints, etc., the image performance will be degraded or the surface of the transparent spherical cover will be scratched. Once dirt is found, please treat it as follows.

- Dust contamination: Use an oil-free soft brush or a blowing ball to gently bounce off dust.
- Grease or fingerprints: gently wipe off the water drops or oil with a soft cloth and dry it, then wipe it from the center to the outside with oil-free cotton cloth or lens cleaning paper dipped in lens cleaning solution. If it is still not wiped, you can change cloth and wipe it several times.

### 7.3 Maintenance of Infrared Camera Glass

Wipe dust, water droplets or oil gently with a soft cloth and dry it, then wipe it from the center to the outside with oil-free cotton cloth or lens cleaning paper dipped in alcohol or lens cleaning solution. If it is still not wiped, you can change cloth and wipe it several times.

### 7.4 Network Security Maintenance

It is recommended that you conduct regular network security assessment on the network camera system, and our company can provide corresponding professional technical services.

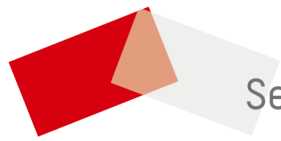

See Far, Go Further