

Fixed-angle Speed-measuring Radar

Narrow beam Speed measurement Radar sensor measures the speed and distance of an approaching or receding vehicle in a single lane. The radar sensor provides a trigger signal for video surveilling equipment in order to capture the target vehicle's number plate. The narrow beam antenna meets the international requirements for speed enforcement radar systems. This module enables an easy integration as there are no settings required. It can be widely applied to highway, tunnel, three-dimensional crossing bridges and other traffic environments.



Model description

The SAP code	Product model	Functional description
302102126	DS-TD10N-1 Fixed-angle Speed-measuring Radar	Fixed-angle Speed-measuring Radar adopts advanced microwave and high accuracy positioning technology, which is suitable for real-time velocity measurement and fixed-point snapshot. Combined with advanced signal processing technology, distance detection for multiple targets can be achieved. All these designs enable vehicles with different speeds or sizes can be triggered to capture the number plate at fixed-spot positions.

Main features

- ▶ High performance radar operates in 24 GHz ISM Band;
- ▶ Special microstrip antenna design effectively avoids interference from adjacent channel target;
- ▶ Accurate speed and distance measurement for multiple targets;
- ▶ High dynamic speed measurement range with very high capture rate;
- ▶ Add Wi-Fi to set parameters simply and fast;
- ▶ Advanced DSP technology, highly accurate speed measurement & very low false alarm rate;
- ▶ Simple installation and convenient in maintenance;
- ▶ Sensor performance unaffected by harsh weather conditions.

Typical application

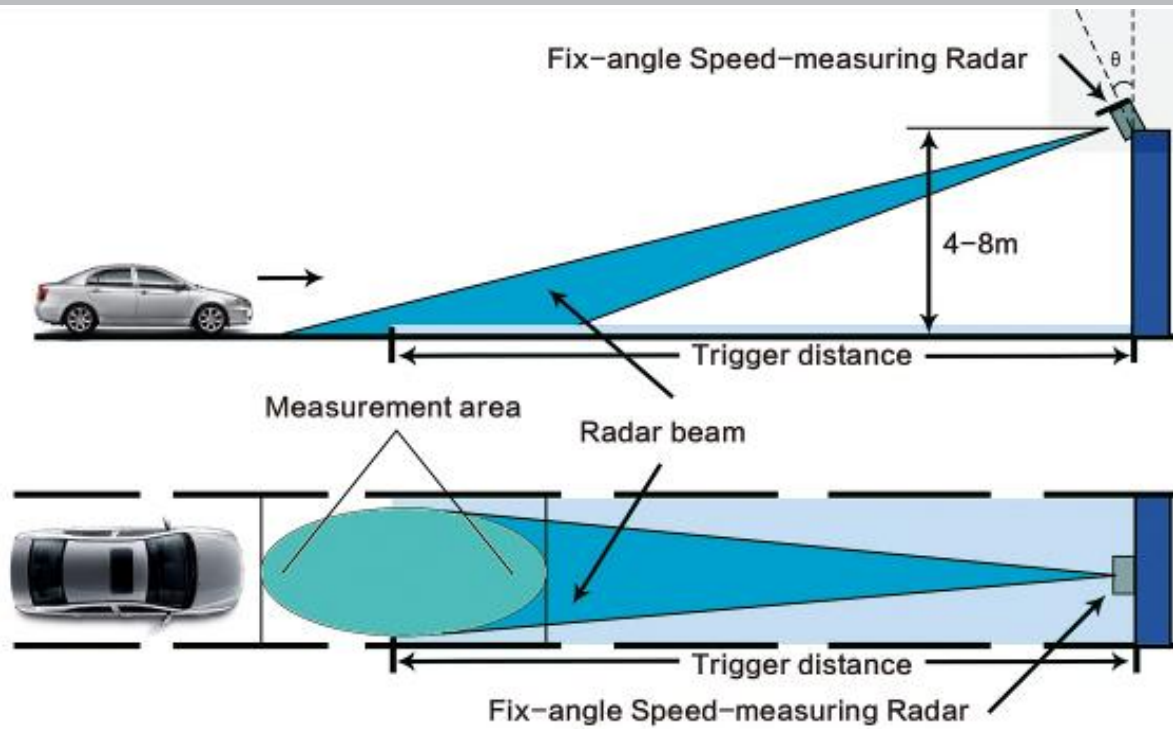

Application diagram

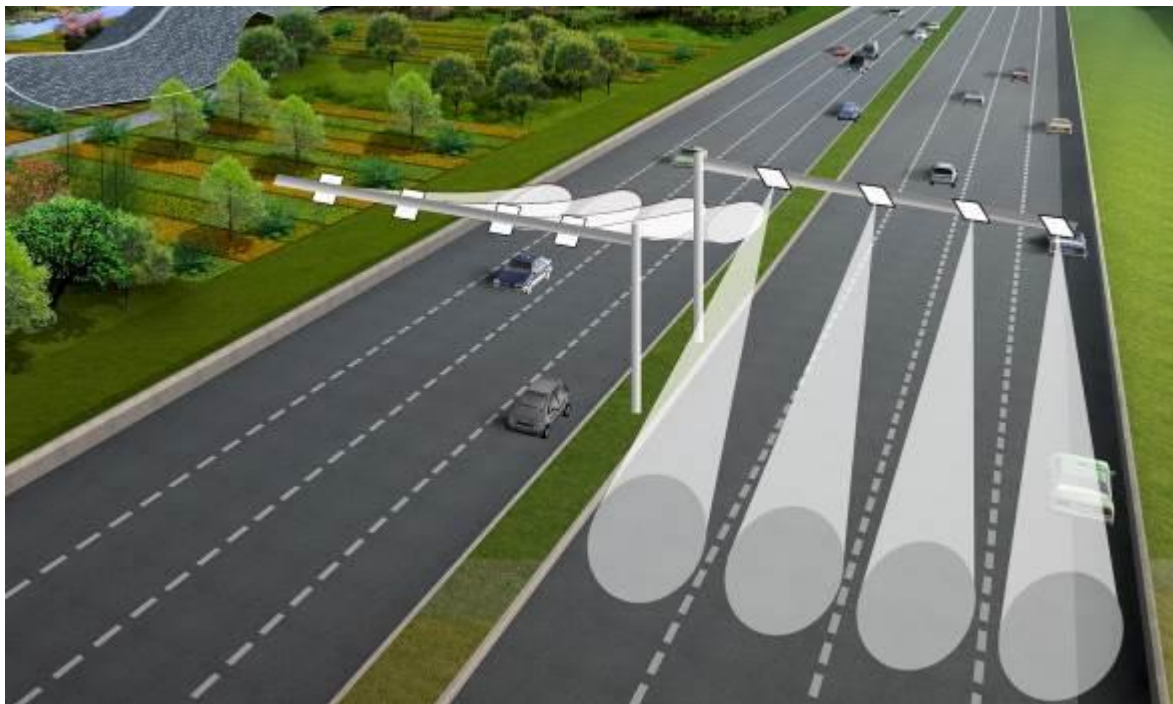

Roads application

Technical parameters

- Central Frequency: 24.15 GHz
- Central Frequency Deviation: $\leq \pm 45$ MHz

- Antenna Beam Width: $6^{\circ} \times 6^{\circ}$
- Capture distance: single lane 18 to 28 m
- Velocity range: 5 km/h to 250 km/h
- Degree of exactitude: (-4 to 0) km/h
- Triggering accuracy: $\leq \pm 1$ m
- Communication Interface: RS-485 (RS-232 optional)
- Temp range: -40°C to $+70^{\circ}\text{C}$
- Humidity range: 5% RH to 95% RH
- Power Supply: 9 V to 12 V DC
- Protection: IP67

Overall dimensions

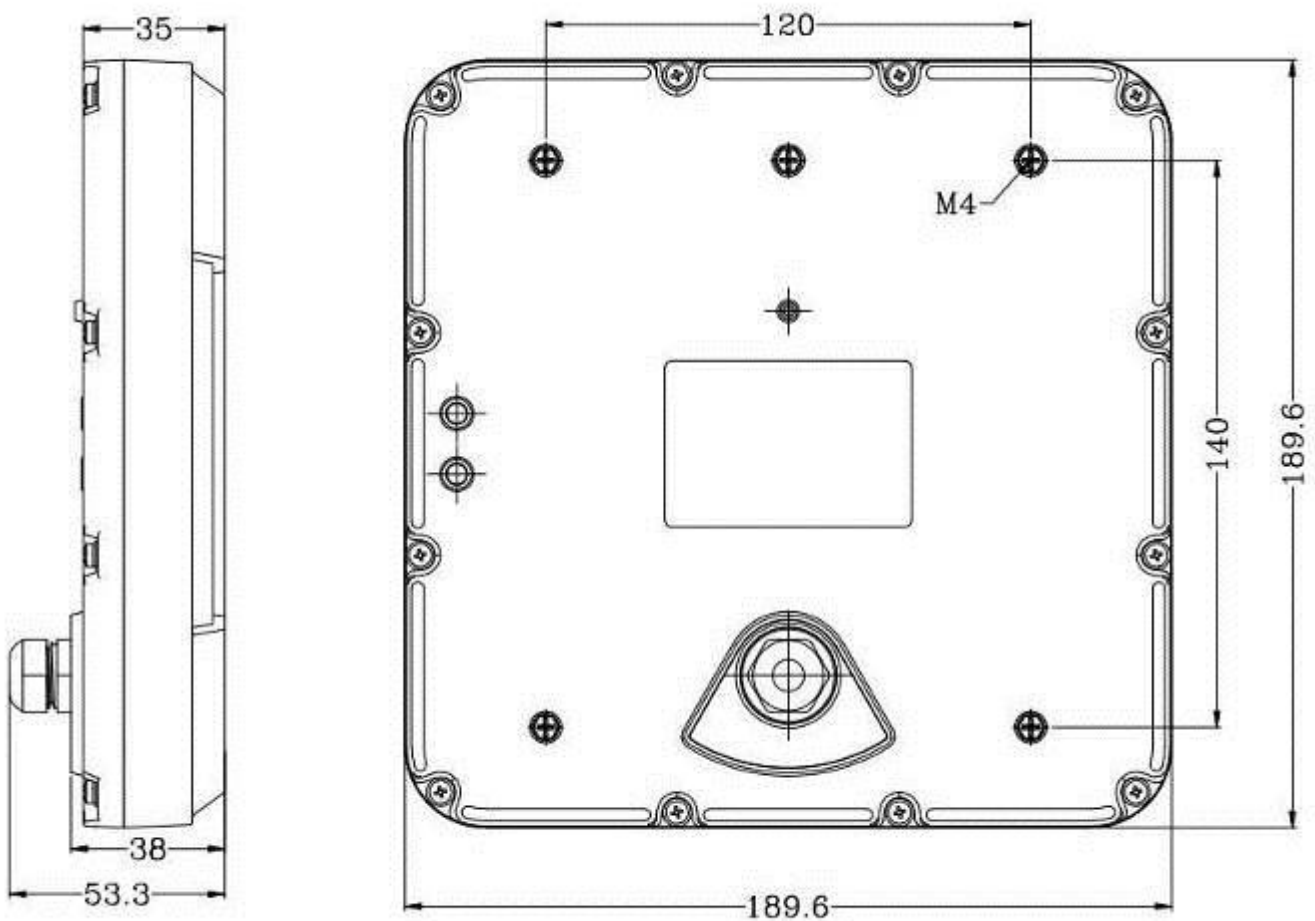

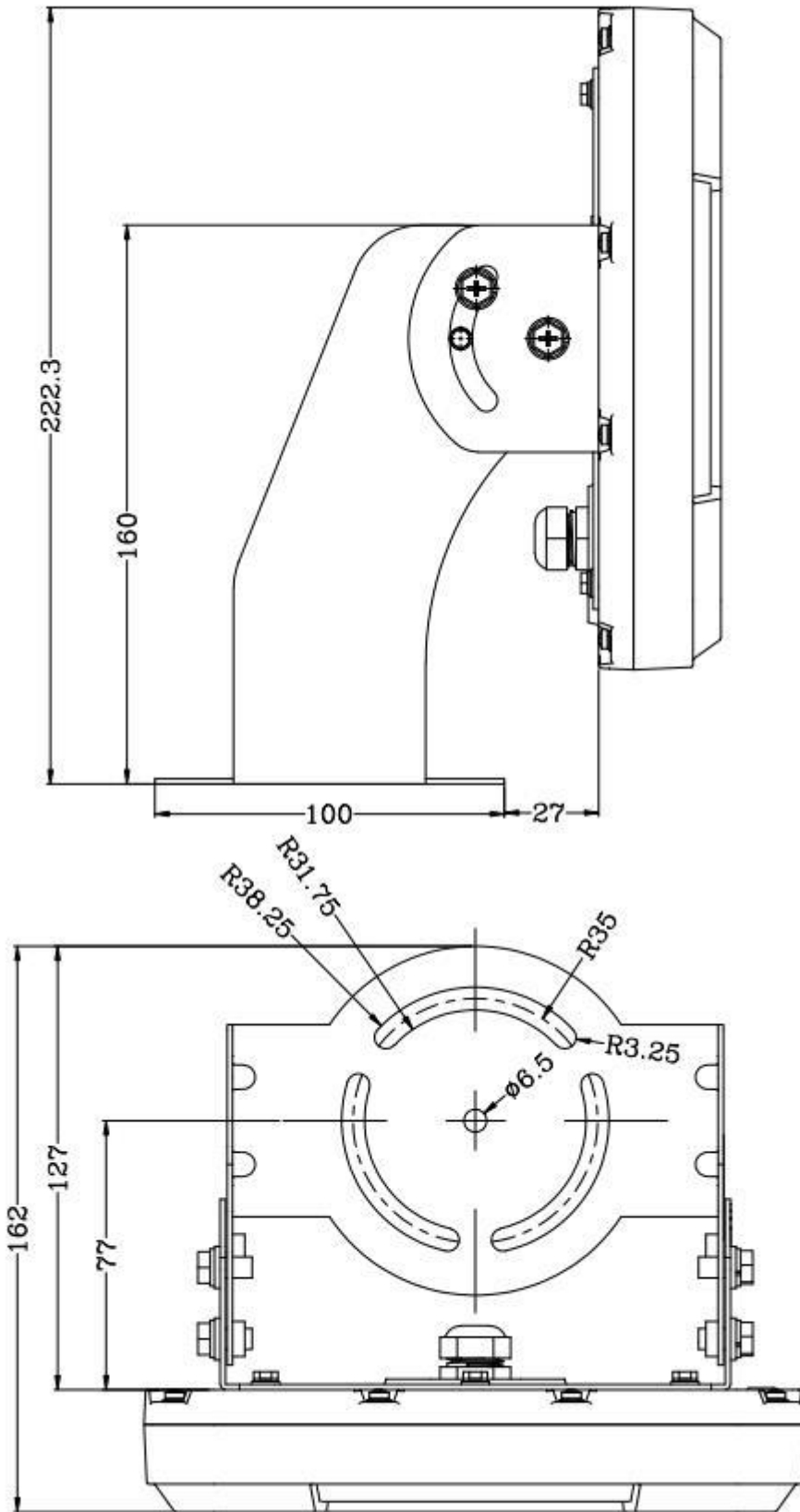

Unit: mm