

YJP7681-188-R(L) Radar Speed Sign LED Display



Radar Speed Sign LED Display makes it convenient for drivers and all round, to see the real-time speed. Drivers can be reminded to keep speed within limits. Moreover, with user-friendly web client, operators can configure it easily.

- Adopts high-frequency band and millimeter-wave radar, supporting to work in all-weather conditions.
- Max. 100 m detection distance and up to 32 targets can be detected.
- Supports to set the speed threshold.
- Supports to install on the lane or at the sides of the lane. Easy installation and debugging.
- Supports displaying speed information through color-coding: when the vehicle's speed is within the allowed limit, the speed value appears in green with a smiley face icon. Conversely, when the vehicle's speed exceeds the upper speed limit, the speed value is displayed in red with a sad face icon.
- High flux and low power LED technology.
- Placed in Enclosed Area, Industrial Park, Enterprise Park, Campus and Port, etc., displays the information of speed.
- Max. visible distance is up to 100m, makes driver notice the information in time.

▪ Specification

Radar	
Working Frequency	60 to 62 GHz
Detection Distance	Up to 100m
Speed Measuring Range	10 to 250 km/h
Max. Detectable Targets	Up to 32
Antenna Beam Width	120° × 16°
Coverage Lanes	Up to 3 lane(s)
Modulation Waveform	FMCW
Capture Rate	≥ 95%
Network	
Protocols	TCP/IP,HTTP,DHCP
User/Host	Up to 16 users,3 user levels: administrator, operator, and user
Security	Password protection,HTTPS encryption,IP address filter,Control timeout settings
Web Browser	Chrome V61+, IE9 to IE11, Firefox V41+, Edge
Wireless (Wi-Fi)	
Encryption Mode	WPA-PSK/WPA2-PSK
Wi-Fi Protocol	IEEE802.11b,IEEE802.11g,IEEE802.11n
Frequency Range	2.4 GHz to 2.484 GHz
Channel Bandwidth	20/40 MHz
Modulation	802.11b: CCK/QPSK/BPSK,802.11g: OFDM,802.11n: OFDM
Wireless Range	Up to 50 m (The performance varies based on actual environment.)
Wireless (Mobile Communication)	
Frequency	-RL model: LTE FDD: Band 1/3/5/7/8/20/28 LTE TDD: Band 38/40/41 WCDMA/HSPA+: Band 1/5/8 GSM/GPRS/EDGE: 900/1800MHz
Standard	LTE-TDD,LTE-FDD,GPRS,GSM,CDMA
SIM Card Type	Nano SIM
Interface	
Ethernet Interface	1 RJ45 10M/100M self-adaptive Ethernet port(s)
On-Board Storage	Built-in eMMC 2G
RS-485	1 RS-485
Warning Screen	
Central Light Strength	≥ 3000cd/m ²
LED Visual Angle	> 100°
LED Service Life	≥ 100,000 hours
LED Pixel Pitch	10 mm
Road Traffic and Vehicle Detection	
Smart Function	-RL model: Traffic flow
General	
Power	DC 12 V ± 5%, 5 A, 2-core terminal block, 1. The average power consumption: 25 W (4G transmission is cluded), 2. The max. power consumption: 60 W

Material	SECC
Dimension	759 mm × 96 mm × 810 mm (29.88" × 3.78" × 31.89") (L × W × H)
Package Dimension	930 mm × 250 mm × 988 mm (36.6" × 9.84" × 38.9") (L × W × H)
Weight	Approx. 16.8 kg (37 lb.)
With Package Weight	Approx. 18.8 kg (41.4 lb.)
Operating Condition	-30 °C to 70 °C (-22 °F to 158 °F). Humidity 95% or less (non-condensing)
Storage Condition	-30 °C to 70 °C (-22 °F to 158 °F). Humidity 95% or less (non-condensing)
General Function	Remote config via WiFi, Customized LED display(Chinese, English, Spanish, Portuguese), Password protection
Approval	
RF	CE-RED:EN 301489-1 V2.2.3, EN 301489-3 V2.1.1, EN 301489-17 V3.2.4, EN 301489-52 V1.2.1, EN 302264-1 V1.1.1, EN 302 264-2 V1.1.1, EN IEC 62311:2020, EN 300328 V2.2.2, EN 301511 V12.5.1, EN 301908-2 V13.1.1, EN 301908-1 V15.2.1, EN 301908-13 V13.2.1, ETSI TS 136521-1 V18.4.0, EN 305550-2 V1.2.1
EMC	CE-EMC: EN 55032: 2015+A11:2020+A1:2020, EN 55035: 2017+A11:2020, EN 61000-3-3: 2013 +A1:2019+A2:2021, EN IEC 61000-3-2: 2019+A1:2021+A2:2024, EN IEC 61326-1: 2021
Safety	CE-LVD: EN IEC 62368-1:2020+A11:2020, CE-LVD: EN 61010-1:2010+A1:2019 CB: IEC 62368-1:2018, CB: IEC 61010-1:2010, IEC 61010-1:2010/AMD1:2016
Environment	CE-RoHS: 2011/65/EU,WEEE: 2012/19/EU,Reach: Regulation (EC) No 1907/2006
Protection	IP66: IEC 60529-2013

▪ Typical Application

Hikvision products are classified into three levels according to their anti-corrosion performance. Refer to the following description to choose for your using environment.

This model has NO SPECIFIC PROTECTION.

Level	Description
Top-level protection	Hikvision products at this level are equipped for use in areas where professional anti-corrosion protection is a must. Typical application scenarios include coastlines, docks, chemical plants, and more.
Moderate protection	Hikvision products at this level are equipped for use in areas with moderate anti-corrosion demands. Typical application scenarios include coastal areas about 2 kilometers (1.24 miles) away from coastlines, as well as areas affected by acid rain.
No specific protection	Hikvision products at this level are equipped for use in areas where no specific anti-corrosion protection is needed.

▪ Dimension

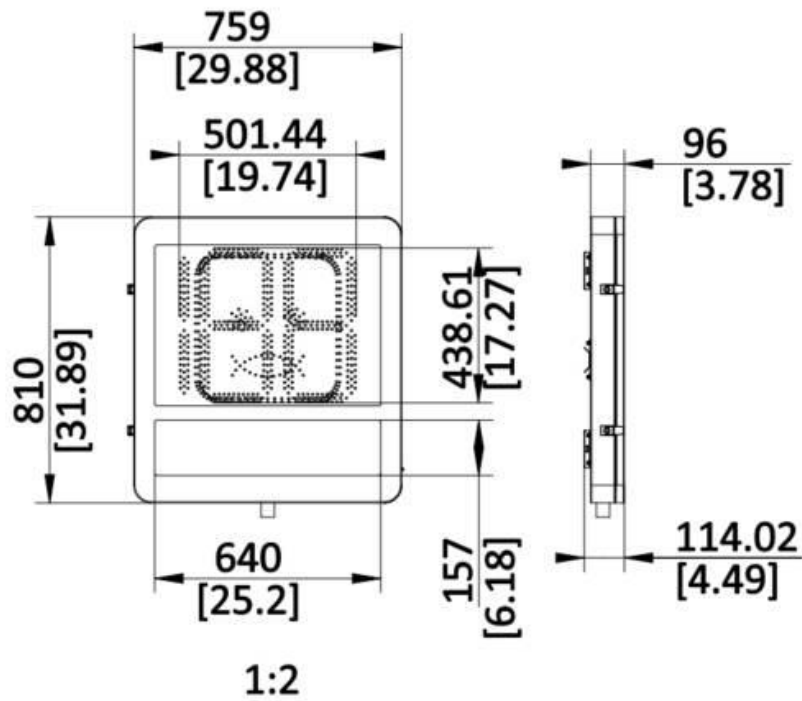

L × W × H: 759 mm × 810 mm × 96 mm (29.88 × 31.89 × 3.78)

Camera Mounting Hole[mm]	Camera Mounting Hole[inch]	Unit: mm [inch]	
		SCALE	1:1

See Far, Go Further



www.hikvision.com
support@hikvision.com

