

**DS-1697ZJ-X-AC(OS)**  
**Anti-corrosion Pendant Mount**



- Electro-polished stainless steel 316L
- Cable hole design facilitates the installation
- Applies to anti-corrosion dome camera

▪ Specification

Parameters	
Weight	1.2 kg (2.65 lb.)
Appearance	Stainless steel natural color
Material	Electro-polished stainless steel 316L
Dimension	136 mm × 204.2 mm × 353 mm (5.35" × 8.04" × 13.90")

▪ Dimension

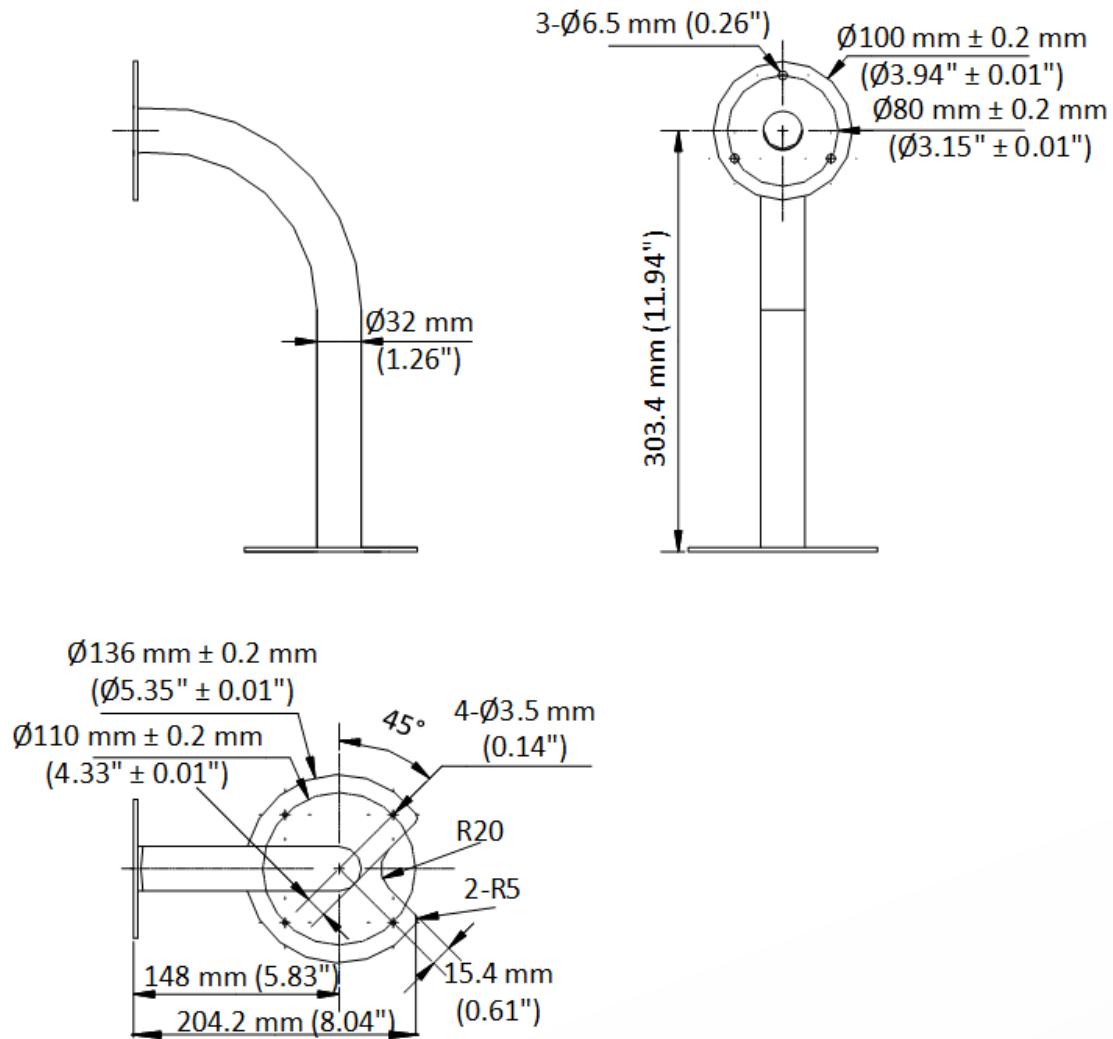

▪ Accessory



DS-2XE6786G0-LIZHS/AM(316L)



DS-2XE6746G0-LIZHS/AM(316L)



DS-2XE6146F-HS  
(C)



DS-2XE6126FWD-HS(B)



DS-2XE6146F-HS(B)

# See Far, Go Further



[www.hikvision.com](http://www.hikvision.com)  
[support@hikvision.com](mailto:support@hikvision.com)

